



Bearingless Rotating Unions



Series

CCM

for use of water as medium.

Content

1	For your Safety	3
1.1	Intended Use	3
1.1.1	Application one-way version (Mono)	3
1.1.2	Application two-way version (Duo)	4
1.2	Misuse	4
1.3	Safety Instructions	5
1.3.1	Hazards due to hot media	5
1.3.2	Hazards by faulty installation	5
1.4	Structure of Pictograms	5
2	Information as to this Manual	5
3	Information on the Name Plate	6
4	Information on the Design	6
4.1	Components of Rotating Unions (Mono/Duo)	6
4.2	Fit, Shape and Positional Tolerances	7
4.3	Mounting Direction of Bushing	7
4.4	Prepare Installation of Rotating Union	7
4.5	Ensure Drainage of Leaking Medium	7
5	Installation	8
6	Information on the Operation	8
7	Storage	8
8	Maintenance	8
8.1	Maintenance Intervals	8
8.2	Daily Inspection	9
9	Trouble Shooting	9
9.1	Potential Causes for Errors and their Elimination	9
9.2	Pack Rotating Union for Transport	10
10	Disposal	11
10.1	Dispose of Packaging	11
10.2	Dispose of Rotating Union	11
11	Spare Parts	11

1 For your Safety

This chapter provides information on the safe handling of *DEUBLIN* Bearingless Rotating Unions.

- ❑ For your own safety and the safety of other people read this operating manual carefully and completely prior to working on or with *DEUBLIN* rotating unions.
- ❑ This operating manual exclusively describes the rotating unions of the manufacturer *DEUBLIN*. In the further description/explanation the name “*DEUBLIN*” is left out for a better readability.
- ❑ This operating manual is a material part of the specified rotating unions. The operator is responsible for the personnel to take note of this manual.
- ❑ Always use the latest version of the operating manual, available under www.deublin.eu.
- ❑ The operator of the rotating unions shall not make any modifications or attachments to and retrofitting of the rotating union without the manufacturer’s consent.
- ❑ Please follow the additional instruction „Installation“ for a secure and correct installation of the rotating union. The installation instruction is included with the delivered union.

1.1 Intended Use

The rotating unions of the series CCM supply the feeding of water for continuous casting plants in the steel industry. The fed water cools the rollers.

max. pressure (bar)	N _{max.} GMU (min ⁻¹)	Temperature range (°C)
10	20	3 up to 90 ⁽¹⁾

¹⁾ If you need the rotating unions for higher temperatures of the medium, consult with *DEUBLIN*.

The rotating unions of CCM series are designed for non-potentially explosive environments and non-combustible media.

For information on the range of use of the rotating unions, please refer to the catalogue and/or the model-specific installation drawing.

Depending on the connection, the rotating unions of CCM series can be used as one-way or two-way version.

1.1.1 Application one-way version (Mono)

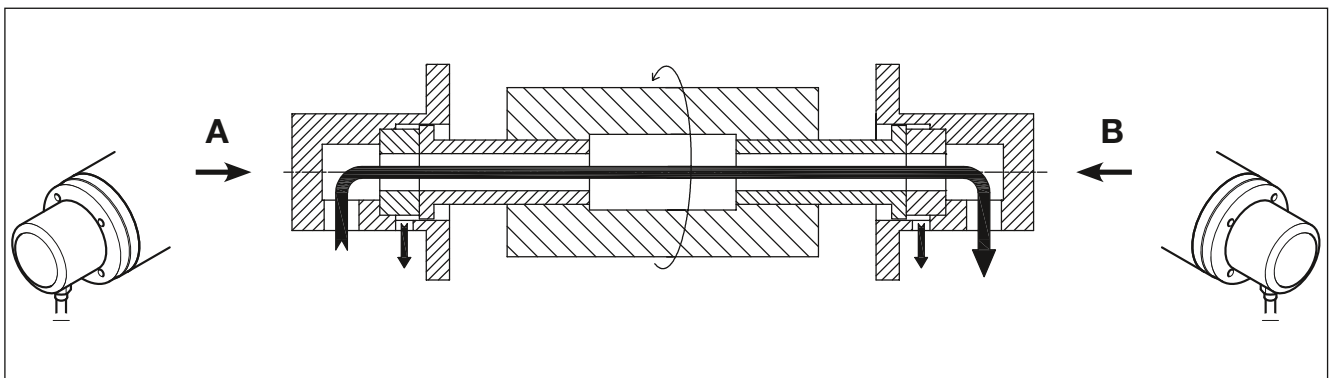
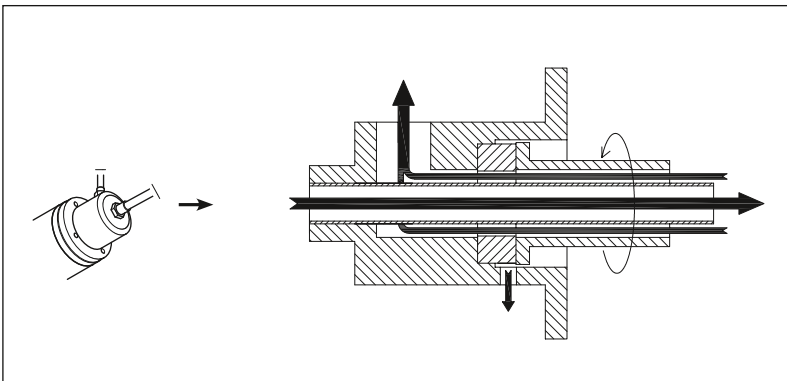

Fig. 1: Schematic diagram one-way version (Mono – outside installation)

One one-way version of the rotating union is mounted at each of the two ends of the roller. The rotating union **(A)** conveys the medium into the roller. The rotating union **(B)** conveys the medium into the piping system of the machine.

1.1.2 Application two-way version (Duo)



At one end of the roller a rotating union is installed which conveys the medium in the roller and then in the piping system of the machine.

Fig. 2: Schematic diagram two-way version (Duo)

1.2 Misuse

This chapter provides information on known misuse of rotating unions of the CCM series. The rotating unions are not suitable for the areas and applications described herein. Use in such areas or for such applications constitutes a misuse endangering people and machines and is therefore prohibited.

Prohibition for the following areas:

Potentially explosive rooms

The rotating unions of the CCM series shall not be used in potentially explosive rooms, as they are not approved for the requirements in potentially explosive rooms. Operation in such rooms may cause explosions.

Food

Food, cleaning and disinfectant residues cannot be removed from the rotating unions. People may suffer poisoning.

Prohibition for the following applications:

Conveying of combustible media or hydrocarbons

Combustible media or hydrocarbons may ignite or cause explosions.

Connection to a piping system with excessive pressure

If excessive pressure is applied to the rotating unions, the connections may become leaky and personal injury or property damage may be caused by escaping medium.

Operation without lubrication

Dry operation (without medium) of the rotating union causes damages to the axial face seals.

Conveying of media with a temperature below 3 °C

If you convey a medium with a temperature below 3 °C through the rotating union, the latter will be damaged.

Conveying of vapour

Vapour damages the rotating union. Escaping vapour may injure people seriously.

This list is not comprehensive and will be updated with results from product observation.

1.3 Safety Instructions

This chapter provides information on the hazards through rotating unions.

1.3.1 Hazards due to hot media

The rotating unions are heated by the temperature of the medium. Skin contact with heated rotating unions can cause injuries.

- Use safety gloves protecting against heat when handling the rotating union.
- Attach a clearly visible danger sign visibly on/next to the rotating union in order to warn of danger.

1.3.2 Hazards by faulty installation

In case of faulty installation of the rotating unions, the connections and O-rings of the rotating unions may become leaky. The medium may escape. Depending on the medium, people may be injured and components of the machine may be damaged.

- Before installing the rotating union ensure that no feed pressure and no residual pressure is applied to the pipeline system of the machine.
- Prior to installation, make sure that the O-rings are positioned correctly in the recesses of the rotating union.
- Make sure the fixings of the rotating union are tightened in the correct sequence.
- Install the rotating union in a way that the leaking medium can be carried away downward at the lowest point.

1.4 Structure of Pictograms

This chapter provides information on the meaning of the pictograms used in the manual.



Warning

Warning

Potentially dangerous situation, which may result in death or serious injury.



Note

Note

Potentially harmful situation in which the product or surrounding objects can be damaged.



Info

Application notes

and other useful information.

2 Information as to this Manual

The copyright as to this manual remains with *DEUBLIN*. Subject to changes!

- You can download the latest version of this manual under www.deublin.eu.
- Always use the latest version of the operating manual.

3 Information on the Name Plate

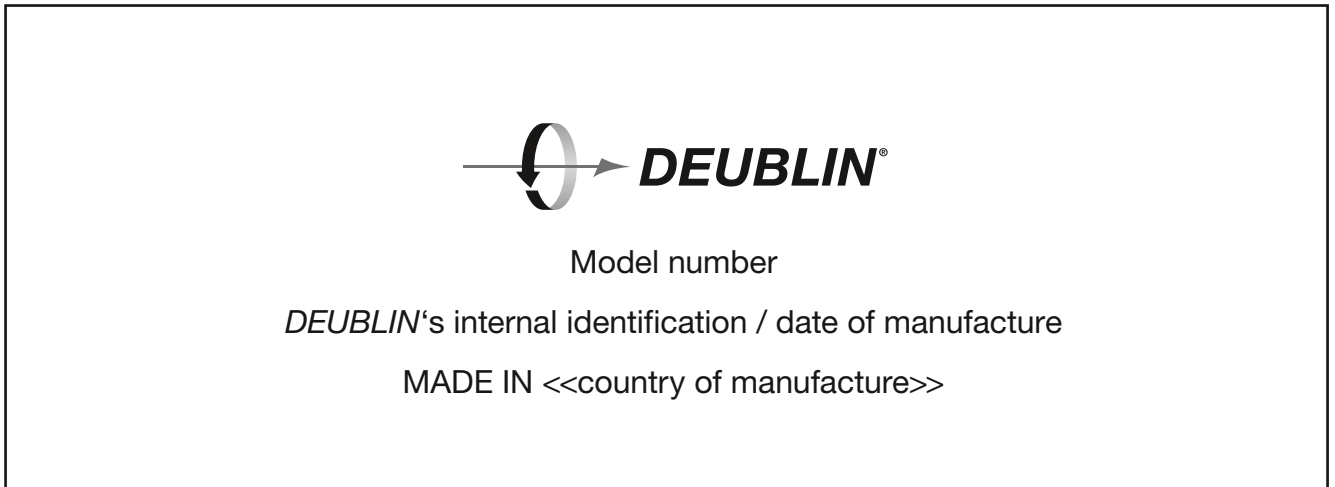

Fig. 3: Name plate

The coding of the model number is described in the catalogue. The model number corresponds to the order number.

4 Information on the Design

This chapter provides information as to which items have to be observed in the design in order to have a positive effect on the service life of the rotating union.



You can obtain the drawings of the rotating unions from *DEUBLIN* in order to integrate the rotating union in your drawing.

You will require the model-specific installation drawing of your rotating unions to implement it into your design and to operate the rotating unions in a safe manner.

4.1 Components of Rotating Unions (Mono/Duo)

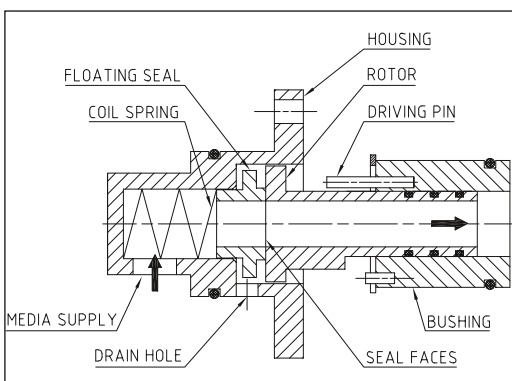

Figures 4 and 5 show the most important components of a rotating union. The models of CCM series may deviate from the figures. All models feature the same design and are comparable to the shown figures.

Fig. 4: One-way version (Mono)

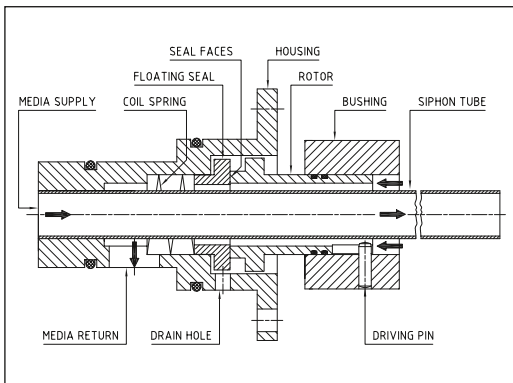

Fig. 5: Two-way version (Duo)

4.2 Fit, Shape and Positional Tolerances

Functioning of the rotating unions is only ensured, if you observe the specifications of *DEUBLIN* regarding design of fits, shape and positional tolerances. If you do not observe them, O-rings etc. may be damaged. The medium may escape. Corresponding information can be found in the technical drawing of the rotating union.

- Make sure that all specifications by *DEUBLIN* on the installation of the rotating union in your machine are observed.

4.3 Mounting Direction of Bushing

The bushing is inserted in the bore of the journal. It transmits the rotating movement of the roll to the rotor of the rotating union. For this purpose, the bushing is provided with a drive pin. Depending on the type of bushing, the drive pin is installed on the bushing axially or radially. The rotating union is slipped on the drive pin.

- Consider the mounting direction of the bushing in the design in order to be able to slip the bushing on the drive pin when installing it.

4.4 Prepare Installation of Rotating Union

Sharp edges of the bore of the journal may damage the O-rings of the rotating union.

- Provide the bore of the journal with a chamfer of 30° in order to prevent the O-rings from being damaged when pressing them in.

4.5 Ensure Drainage of Leaking Medium

The rotating unions are provided with a vent hole. Complete draining of leaking medium can only be ensured, if the vent hole is in 6 o'clock position.

- Position the rotating unions in a way that the vent hole is always in 6 o'clock position (at the lowest point).

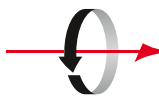

5 Installation

The union installation is described in an additional manual which is supplied with each rotating union. Please follow the additional instruction "Installation" for a secure and correct installation of the rotating union. The instruction "Installation" is available online under www.deublin.eu.

- Ensure that the person installing the rotating union receives the following information:
 - Position and location of the rotating union in the machine
 - Connection plan of piping system
 - Position of leakage line
 - Information on the media

6 Information on the Operation



Note

Damage to components due to missing lubrication

The axial face seals of the rotating unions are lubricated by the medium. If the rotating unions are operated without medium, they are not lubricated and will thus be damaged.

- Ensure that the rotating unions are operated with a medium.
- Switch off the plant/machine, if the rotating unions are operated without medium.



Note

Damage by cold media

If you convey a medium with a temperature below 3 °C through the rotating union, the latter will be damaged.

- Use the rotating unions only with media with a temperature above 3 °C.

7 Storage



Note

Damage of component due to incorrect storage

If you store the rotating unions incorrectly, they become leaky or get damaged.

- Store the rotating unions in a dry space between 3 °C and 40 °C.
- Store rotating unions for two years at the most.

8 Maintenance

This chapter provides information on how to extend the service life of the rotating unions by means of maintenance.

8.1 Maintenance Intervals

Rotating unions of CCM series are maintenance-free.



Warning

Risk of injury due to hot surfaces

The rotating unions are heated by the temperature of the medium. When touching this heated rotating union, severe injuries may be caused.

- Before starting to work on the rotating unions, allow the machine to cool.
- Depending on the application of the rotating union, use gloves protecting against heat.

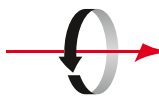

Note

Damage of component due to old bushing

If you operate an old bushing with a new rotating union, the latter may be damaged.

- Always replace rotating union and bushing.

8.2 Daily Inspection

Check the rotating unions for tightness.



Warning

Risk of injuries due to applied line pressure

If you have to work on the rotating union and feed pressure of the medium is applied or there is residual pressure in the piping system of the machine, the medium can escape under pressure when releasing the connections. You and other people may suffer severe injuries.

- Ensure that no feed pressure is applied.
- Ensure that there is no residual pressure in the piping system.

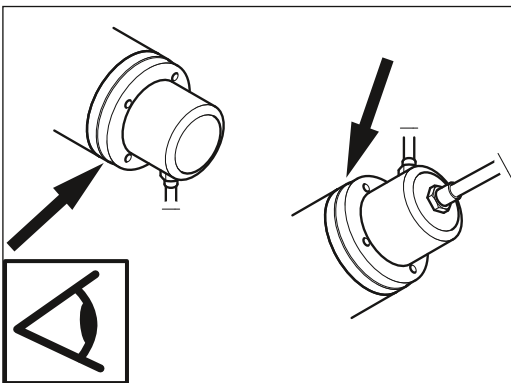

Fig. 6: Inspect visually

During operation of the machine, leakages may occur at the connecting flange depending on the requirements to the rotating unions.

- Carry out daily visual inspections in order to check whether leakages occurred at the connections (see arrows).

If you detect leakages:

1. Stop the machine.
2. Seal leaking connections.
3. If the rotating union is worn and leaks, replace it by a new one. In doing so, always replace rotating union and bushing. Repair kits for various models can be obtained from DEUBLIN.

9 Trouble Shooting

This chapter provides the following information:

1. Which errors may occur?
2. What can be the cause of the error?
3. How can you eliminate this error?

9.1 Potential Causes for Errors and their Elimination



Warning

Risk of injuries due to applied line pressure

If you have to work on the rotating union and feed pressure of the medium is applied or there is residual pressure in the piping system of the machine, the medium can escape under pressure when releasing the connections. You and other people may suffer serious injuries.

- Ensure that no feed pressure is applied.
- Ensure that there is no residual pressure in the piping system.

Error	Potential causes	Elimination
Rotating union is leaky after installation	Incorrect installation	1. Stop the machine. 2. Ensure that the connections are sealed according to the manual "Installation". 3. Make sure that all seal faces are clean. 4. Make sure that the O-rings are in the correct position.
	Seal faces of the rotating union are damaged	1. Pack rotating union 2. Send rotating union to <i>DEUBLIN</i> for overhaul/service.
	Rotating union is defective	
Rotating union leaks before the end of the expected service life.	The rotating union is not designed for the case of application.	1. Ensure that the correct <i>DEUBLIN</i> Rotating Union is used. 2. Contact <i>DEUBLIN</i> if required.
	The medium shows impurities.	1. Check filter system of the machine; clean and install new filter, if applicable.
No flow through rotating union.	Incorrect position of rotating union, incorrect installation of flange.	1. Shut down machine. 2. Drain medium. 3. Release flange at rotating union, align feed and return conduit, observe coded screw position and use correct number of screws.

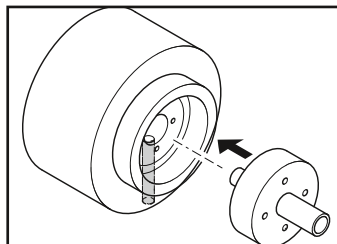

9.2 Pack Rotating Union for Transport

The rotating union has to be protected against mechanical impact and humidity during transport to ensure that the rotating union will arrive at *DEUBLIN* without being damaged.

1. Dismount the rotating union in reverse order of the installation (see Installation).
2. Ensure that the rotating union is free from the respective media.
3. Use a cardboard box which is suitable for the weight of the rotating union.
4. Cushion the ground of the cardboard box with a soft material, e.g. air bubble film.
5. Wrap the rotating union with a soft material, e.g. air bubble film.
6. Ensure that no packing material or dirt can penetrate the opening of the rotating union.
7. Position the rotating union in the middle of the cardboard box.
8. Fill the free space around the rotating union with newspaper or another suitable material.
9. Close the cardboard box by means of tape.

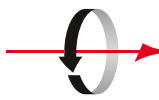

10 Disposal

10.1 Dispose of Packaging

- Dispose of the packaging (cardboard box and plastics) according to the national standards, regulations and directives.

10.2 Dispose of Rotating Union

Mainly, the rotating unions consist of metals, which can be reused within the reclamation of scrap. Decontaminate unions / parts and dispose of in an “Environmentally Friendly” way.

- Dismount the rotating union in reverse order to the installation (see Installation).
- Flush the rotating union.
- Collect the dirty rinsing water.
- Dispose of the collected rinsing water according to the national standards, regulations and directives.
- If you use thermal oil, please observe the instructions of the thermal oil manufacturer.
- Dispose of the rotating union according to the national standards, regulations and directives.

In case of repair, *DEUBLIN* disposes of all used parts.

11 Spare Parts

The rotating unions have a limited service life and include wearing parts. Wearing parts are excluded from the warranty. All static and dynamic sealing elements of a component are considered wearing parts, as well as thrust washers.

Repair kits are available for several models of the rotating unions and can be obtained from *DEUBLIN*. Please ask your *DEUBLIN* Service.

You need special tools and repair instructions for repair of the rotating unions which can be obtained from *DEUBLIN* as well.



Info

Note

If you do not want to repair your rotating union on your own, *DEUBLIN* will be pleased to help you. If requested, *DEUBLIN* will exchange all wearing parts and clean all components of the rotating union. Before repaired rotating unions leave the premises, they will be subjected to an operational check. The repaired rotating union is returned with a standard “*DEUBLIN* Warranty” valid for 12 months.

Reliability

Many years' experience, ongoing liaison with customers, innovations sourced inhouse and from suppliers place *DEUBLIN* in a position providing reliable Rotating Unions at the highest level.

When it comes to concrete applications, maximum service life is guaranteed by matching the sealing to the respective medium.

The service life is also equally maximized by maintaining cleanliness when storing and handling the Rotating Union and by adhering to the guidelines issued by *DEUBLIN* in respect of the conditions on the customer's premises.

EUROPE

DEUBLIN Germany

Florenz-Allee 1
55129 Mainz, Germany
Phone: +49 6131-49980
Fax: +49 6131-4998109
e-mail: info@deublin.de

DEUBLIN Italy

Via Guido Rossa 9 - Loc. Monteveglio
40053 Comune di Valsamoggia (BO), Italy
Phone: +39 051-835611
Fax: +39 051-832091
e-mail: info@deublin.it

DEUBLIN Austria

Lainzer Straße 35
1130 Wien, Austria
Phone: +43 1-8768450
Fax: +43 1-876845030
e-mail: info@deublin.at

DEUBLIN France

61 Bis, Avenue de l'Europe
Z.A.C de la Malnoue, Emerainville
77436 Marne-la-Vallée Cedex 2, France
Phone: +33 1-64616161
Fax: +33 1-64616364
e-mail: service.client@deublin.fr

DEUBLIN Poland

ul. Bierutowska 57-59
51-317 Wrocław, Poland
Phone: +48 71-3528152
Fax: +48 71-3207306
e-mail: info@deublin.pl

DEUBLIN Russia

ul. Kosygina, 13, 5th entrance, 1st floor
Moscow, 119334, Russia
Phone: +7 495-647 1434
Fax: +7 495-938 8949
e-mail: info@deublinrussia.ru

DEUBLIN Spain

C/ Lola Anglada, 20 local 1
08228 Terrassa, Spain
Phone: +34 93-221 1223
Fax: +34 93-221 2093
e-mail: deublin@deublin.es

DEUBLIN United Kingdom

6 Sopwith Park, Royce Close, West Portway
Andover SP10 3TS, UK
Phone: +44 1264-33 3355
Fax: +44 1264-33 3304
e-mail: info@deublin.co.uk

AMERICA

DEUBLIN USA

2050 Norman Drive
Waukegan, IL 60085-6747 U.S.A
Phone: +1 847-689 8600
Fax: +1 847-689 8690
e-mail: customerservice@deublin.com

DEUBLIN Brazil

Rua Fagundes de Oliveira, 538 - Galpão A11
Piraporinha
09950-300 - Diadema - SP - Brasil
Phone: +55 11-2455 3245
Fax: +55 11-2455 2358
e-mail: deublinbrasil@deublinbrasil.com.br

DEUBLIN Mexico

Norte 79-A No. 77, Col. Claveria
02080 Mexico, D.F.
Phone: +52 55-5342 0362
Fax: +52 55-5342 0157
e-mail: deublinmexicocs@deublin.com

ASIA

DEUBLIN China

No. 2, 6th DD Street,
DD Port Dalian, 116620, China
Phone: +86 411-8754 9678
Fax: +86 411-8754 9679
e-mail: info@deublin.cn

Shanghai Branch Office

Room 15A07, Wangjiao Plaza
No. 175 East Yan'an Road, Huangpu District
Shanghai 200002
Phone: +86 21-5298 0791
Fax: +86 21-5298 0790
e-mail: info@deublin.cn

DEUBLIN Asia Pacific

51 Goldhill Plaza
#17-02 Singapore 308900
Phone: +65 6259-92 25
Fax: +65 6259-97 23
email: deublin@singnet.com.sg

DEUBLIN Japan

2-13-1, Minamihanayashiki, Kawanishi City
Hyogo 666-0026, Japan
Phone: +81 72-757 0099
Fax: +81 72-757 0120
e-mail: customerservice@deublin-japan.co.jp

2-4-10-3F, Ryogoku, Sumida-ku

Tokyo 130-0026, Japan
Phone: +81 35-625 0777
Fax: +81 35-625 0888
e-mail: customerservice@deublin-japan.co.jp

1-9-2-4F, Mikawaanjo-cho, Anjo City

Aichi 446-0056, Japan
Phone: +81 566-71 4360
Fax: +81 566-71 4361
e-mail: customerservice@deublin-japan.co.jp

DEUBLIN Korea

Star Tower #1003, Sangdaewon-dong 223-25,
Jungwon-gu, Seongnam-si, Gyeonggi-do,
South Korea
Phone: +82 31-8018 5777
Fax: +82 31-8018 5780
e-mail: customerservice@deublin.co.kr