



Rotating Unions



Series

1600

Content

1	For your Safety	3
1.1	Intended Use	3
1.1.1	Application areas	3
1.1.1.1	Application for each segment (in pairs)	3
1.1.1.2	Application for each segment (individually)	4
1.1.1.3	Application as a slip ring transmitter	4
1.2	Misuse	5
1.3	Safety Instructions	6
1.3.1	Hazards due to hot surfaces	6
1.3.2	Hazards by improper hoses	6
1.3.3	Hazards due to the media	6
1.3.4	Hazards by faulty installation	6
1.4	Structure of Pictograms	7
2	Information as to this Manual	7
3	Information on the Name Plate	7
4	Information on the Design	8
4.1	Filtering of the Medium Water and Coolant	8
4.2	Compressed Air Purity Classes	8
4.3	Definition of Hydraulic Fluids	8
4.4	Connection of the Rotating Union at the Machine Shaft	9
4.5	Options of Hose Installation	9
4.5.1	Connection of hose to the rotating union	9
4.5.2	Using a locking element	10
4.5.3	Connection of a leakage line	10
5	Installation	10
6	Information on the Operation	10
7	Storage	11
8	Maintenance	11
8.1	Maintenance Intervals	11
8.2	Daily Inspection	11
8.3	Maintenance after Operating Hours	12
9	Trouble Shooting	12
9.1	Potential Causes for Errors and their Elimination	12
9.2	Pack Rotating Union for Transport	13
10	Disposal	14
10.1	Dispose of Packaging	14
10.2	Dispose of Rotating Union	14
11	Spare Parts	14

1 For your Safety

This chapter provides information on the safe handling of Deublin rotating unions.

- For your own safety and the safety of other people read this operating manual carefully and completely prior to working on or with Deublin rotating unions.
- This operating manual exclusively describes the rotating unions of the manufacturer Deublin. In the further description/explanation the name “Deublin” is left out for a better readability.
- This operating manual is a material part of the specified rotating unions. The operator is responsible for the personnel to take note of this manual.
- Always use the latest version of the operating manual, available under www.deublin.eu.
- The operator of the rotating unions shall not make any modifications or attachments to and re-fitting of the rotating union without the manufacturer’s consent.
- Please follow the additional instruction „Installation“ for a secure and correct installation of the rotating union. The installation instruction is included with the delivered union.

1.1 Intended Use

The rotating unions in the 1600 series comprise individual segments. Depending on the version, the segments are suitable for hydraulic fluid, water, coolant lubricant, air, inert gasses and vacuum. The channels in the rotating unions are laid out in pairs (one pair per segment). Some media may only be passed through the channels (segments) intended for those particular media.

Refer to the connection diagram and the model-specific installation drawing for further information.

These rotating unions are not permitted in potentially explosive atmospheres or for use with flammable media. Details on the operating parameters of the rotating unions are provided in the catalogue and/or the model-specific installation drawing.

The media that may be used must fulfil specific criteria: see section 4.

1.1.1 Application areas

Described below are a few out of a wide range of various possible areas of application. A particular feature of the 1600 series is that the segment design of the rotating unions permits a single rotating union to be used in the most diverse applications.

1.1.1.1 Application for each segment (in pairs)

This example shows supplying a cylinder with hydraulic oil as the medium.

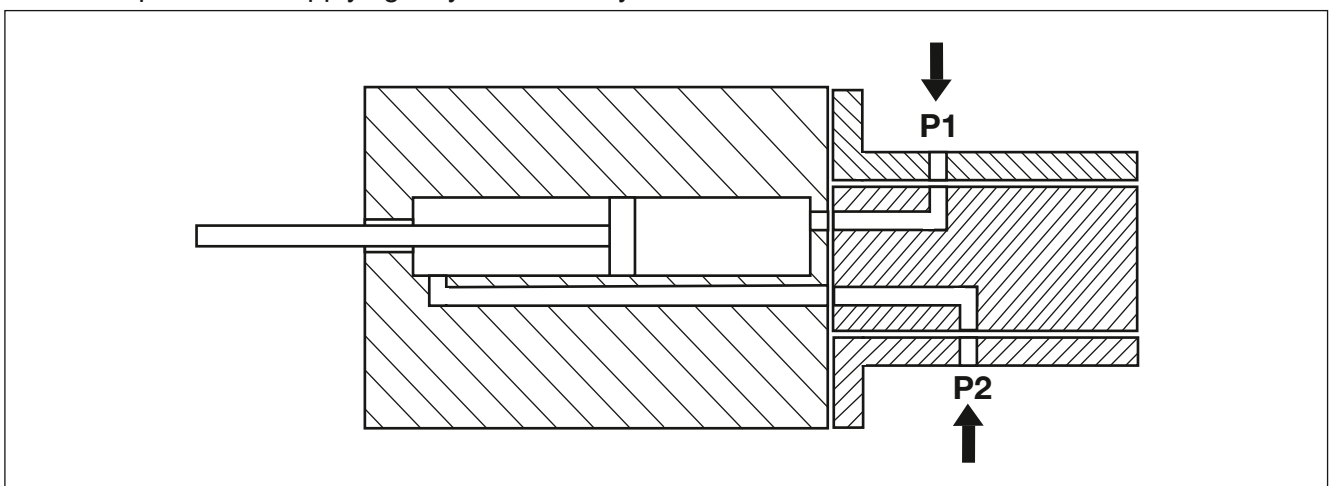

Fig. 1: Schematic diagram for each segment (in pairs)

The hydraulic fluid moves the reciprocating piston in the cylinder. One segment in the rotating union is used for this.

- To extend the piston, hydraulic fluid is passed through connection P1 of the rotating union in front of the reciprocating piston. P2 is pressureless.
- To retract the piston, hydraulic fluid is passed through connection P2 of the rotating union behind the reciprocating piston. P1 is pressureless.

Depending on the complexity of the respective application, additional segments of the rotating union can be operated with other media in order to perform other functions.

1.1.1.2 Application for each segment (individually)

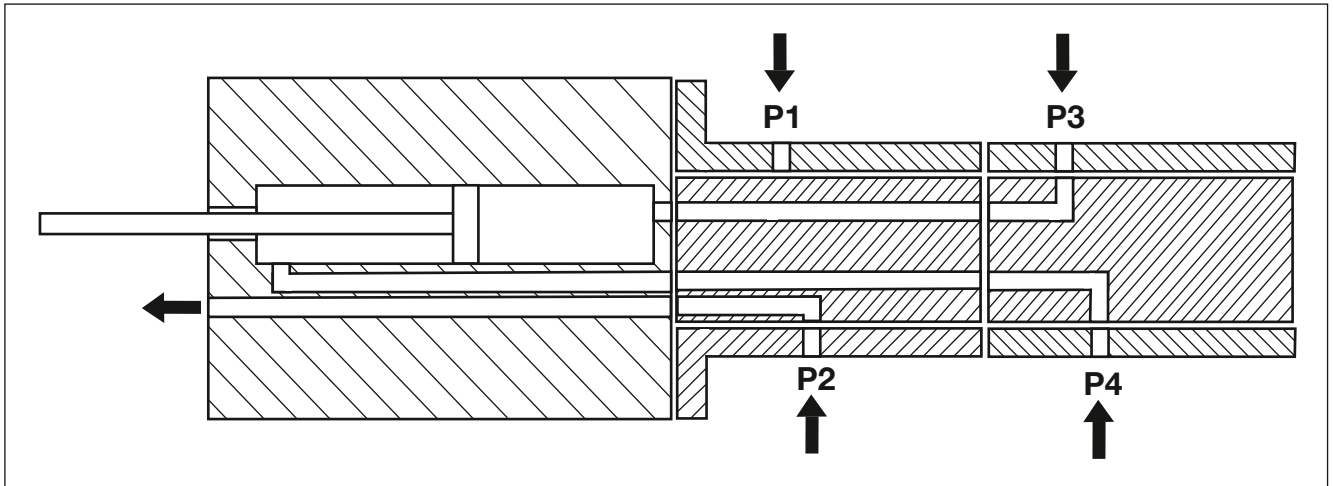

Fig. 2: Schematic diagram for each segment (individually)

The two channels in a segment do not necessarily have to be used in a closed system. For example, compressed air for blowing off can be fed into the machine via one channel. Only one medium can be used per segment. If you do not require the segment for an additional compressed air supply, the second channel remains unused.

1.1.1.3 Application as a slip ring transmitter

Slip ring transmitters can be used to transmit electrical signals or to supply power. Versions with an additional channel (central channel) for cables are available for combined application with a slip ring transmitter.

1.2 Misuse

This chapter provides information on known misuse of rotating unions of the 1600 series. The rotating unions are not suitable for the areas and applications described herein. Use in such areas or for such applications constitutes a misuse endangering people and machines and is therefore prohibited. Always observe the operating data provided by Deublin.

Prohibition for the following areas:

Potentially explosive areas

The rotating unions of the 1600 series shall not be used in potentially explosive areas, as they are not approved for the requirements in potentially explosive areas. Operation in such areas may cause explosions.

Outdoor operation

Inadequate protection against weather conditions can result in premature failure.

Prohibition for the following applications:

Conveying of combustible media or hydrocarbons

Combustible media or hydrocarbons may ignite or cause explosions.

Exception: Thermal oil within the admissible temperature range. Please observe the safety data sheet of the used thermal oil.

Food

Food, cleaning and disinfectant residues cannot be removed from the rotating unions. People may suffer poisoning.

Connection to a piping system with excessive pressure

If excessive pressure is applied to the rotating unions, supply pipes can come off and cause personal injury or property damage.

Operation with central lubrication

If the rotating unions are supplied with grease for relubrication via a central lubricating system, the grease can lose the required properties. This damages the bearings in the rotating unions.

Operation without a medium (dry run)

Operating rotating unions without a medium may damage the sealing surfaces of the rotating union.

Connection to fixed pipes

If connection is via fixed pipes, the rotating unions may leak and the ball bearings may get damaged.

Conveying of media which are too hot

If the media exceed the maximum admissible temperature for the rotating union, the static seals (elastomeric seals) can be damaged which may result in leaky rotating unions and personal injury or property damage.

Application in ambient temperatures/with medium temperatures below 3 °C

Rotating unions may be damaged if they are operated at temperatures (ambient or medium) below 3 °C.

Operation at maximum speed and with maximum pressure

Speed and pressure must be adjusted to each other so that the rotating unions are not damaged or fail prematurely (see model-specific installation drawing).

This list is not comprehensive and will be updated with results from product observation.

1.3 Safety Instructions

This chapter provides information on the hazards through rotating unions.

1.3.1 Hazards due to hot surfaces

The rotating unions are heated by the temperature of the medium and through frictional heat. Skin contact with heated rotating unions can cause injuries.

- Use safety gloves and PPE (Personal Protective Equipment) protecting against heat when handling the rotating union.
- Attach a clearly visible danger sign visibly on/next to the rotating union in order to warn of danger.

1.3.2 Hazards by improper hoses

For the connection of the rotating union to the machine, you have to choose appropriate hoses for the respective medium, which meet the specifications for the application.

If you use incorrect hoses, they may become porous or burst. This can cause personal injury and/or property damage to components of the machine.

- Use only hoses which are suitable for the media, the maximum system pressure and the maximum temperature for the machine.

1.3.3 Hazards due to the media

When working on the rotating union, injuries can be caused by skin or eye contact with the media.

- Observe the safety instructions for the flow media. Observe the COSHH Safety Data Sheet for the flow media.

1.3.4 Hazards by faulty installation

If the rotating unions are installed incorrectly, hoses and connections may become leaky. The medium can escape. Depending on the medium, personal injury or property damage to the components of the machine may occur.

- Before installing the rotating union ensure that no feed pressure and no residual pressure is applied to the pipeline system of the machine.
 - To ensure the safe and proper installation of the rotating union, observe the additional "Installation" instruction manual, which is included with the delivered union.
- Install the rotating union on the machine using hoses only, in order to avoid stress on the rotating union.
- Install the hoses free from stress.
- Install the rotating union in a way that the leaking medium can be carried away securely downward at the lowest point and that the drain line shows a fall (min. 15°).
- Install the hoses to the rotating union prior to mounting it at the machine shaft.
- Install the anti-rotation element on the rotating union, tension free.

1.4 Structure of Pictograms

This chapter provides information on the meaning of the pictograms used in the manual.

**Warning**

Potentially dangerous situation, which may result in death or serious injury.

**Note**

Potentially harmful situation in which the product or surrounding objects can be damaged.

**Application notes**

and other useful information.

2 Information as to this Manual

The copyright as to this manual remains with Deublin. Subject to changes!

- You can download the latest version of this manual under www.deublin.eu.
- Always use the latest version of the operating manual.

3 Information on the Name Plate

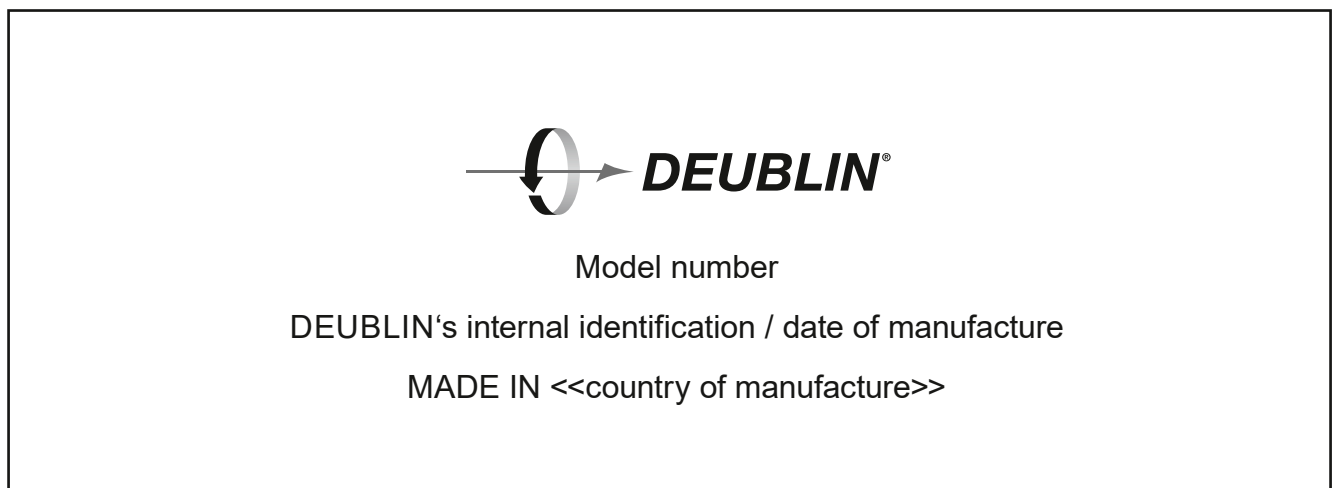

Fig. 3: Name plate

The coding of the model number is described in the catalogue. The model number corresponds to the order number.

4 Information on the Design

This chapter provides information as to which items have to be observed in the design in order to have a positive effect on the service life of the rotating union.



Info

You can obtain drawings of the rotating unions from Deublin in order to integrate the rotating union in your drawing.

You will require the model-specific installation drawing of your rotating unions to implement it into your design and to operate the rotating unions in a safe manner.

The model-specific installation drawing of the respective rotating union contains e.g.:

- torque moments of the union
- technical data
- tolerances
- approved media per segment

4.1 Filtering of the Medium Water and Coolant

Unfiltered media with a particle size of more than 60 µm, increased wear of the rotating union.



Info

The larger the particles in the media, the higher the wear of the rotating union is. The higher the total of all particles (polluting load), the higher the wear is.

- Insert a filter in front of the rotating union which filters particles with a size of 60 µm and larger from the media.
- To ensure the longest possible service life for rotating unions that are used with coolant lubricant, we recommend compliance with purity class 17/15/12 according to ISO 4406:2017 for the media.

4.2 Compressed Air Purity Classes

To ensure the longest possible service life of the rotating union, Deublin recommends using a compressed air purity class according to ISO 8573-1:2010 [6:4:4]. This results in the following parameters for the compressed air:

Particles	Water	Oil
Mass concentration Cp [mg/m ³]	Pressure dewpoint [C°]	Concentration of total oil [mg/m ³]
0 < Cp ≤ 5	≤ +3	≤ 5

4.3 Definition of Hydraulic Fluids

The hydraulic fluid that is used must correspond to the following definition: Mineral oils according to DIN 51524 (HL; HLP)/ ISO 6743/4 (HL, HM, HV) in viscosity classes 10, 22, 32, 46, 68 and 100 mm²/s).

4.4 Connection of the Rotating Union at the Machine Shaft

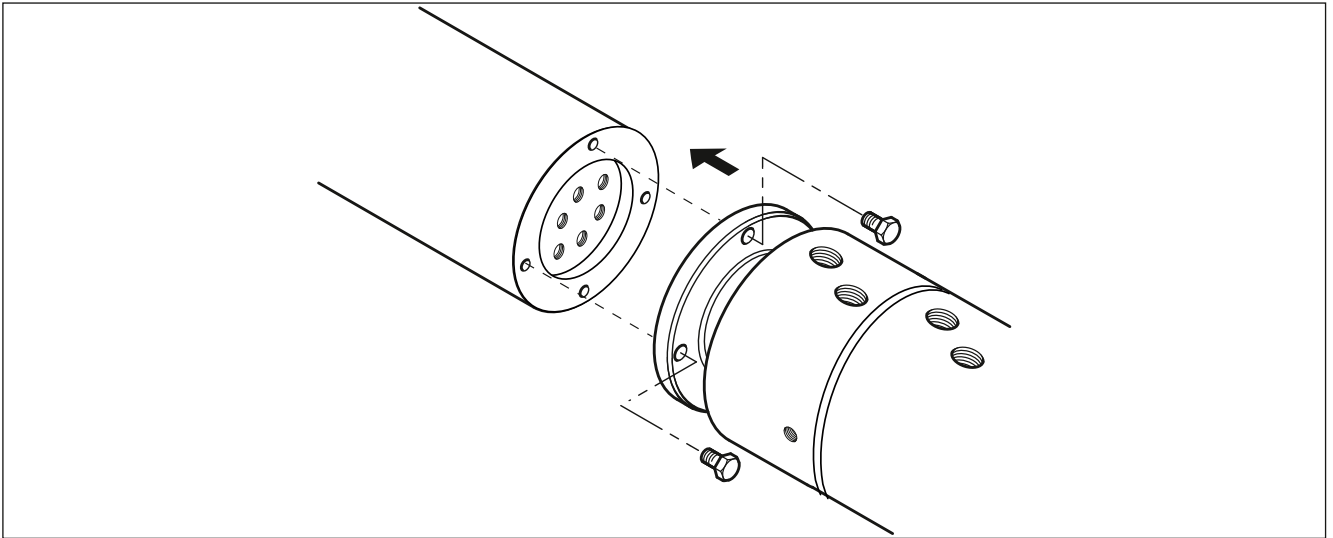

Fig. 4: Installation on the machine shaft

The rotating unions are attached to the machine shaft via the rotor. It is important that the shaft is constructed with appropriate care and in accordance with the specifications given with the rotating union model-specific installation drawing. Deviations may result in leakages and uneven movement of the rotating union.

The rotating unions can be installed horizontally or vertically on the shaft.

4.5 Options of Hose Installation

The following examples show how to install the hoses at the rotating unions.

These connecting options ensure that the hoses do not transfer stress to the rotating unions when the machine shaft moves.

- ❑ Please pay attention to the chapter “1.3 Security Advices” regarding the design.

4.5.1 Connection of hose to the rotating union

The hoses must be installed without stress and bends so that they do not apply any forces to the rotating union.

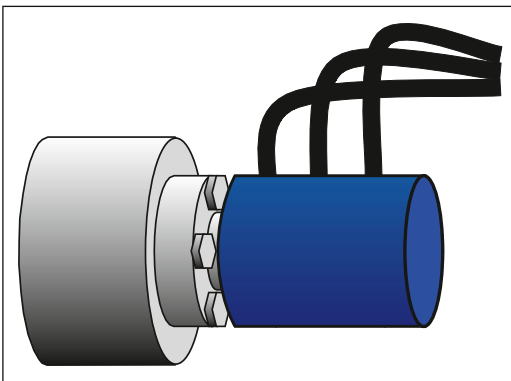

Use flexible hoses to connect the rotating union. Flexible hoses prevent lateral loads from exerting pressure on the rotating union bearings during operation.

Fig. 5: Flexible hose connection

4.5.2 Using a locking element

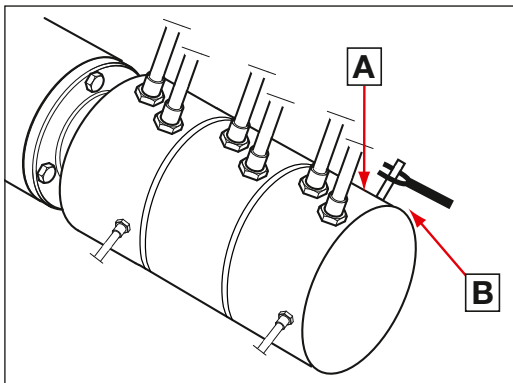

The rotating union housing must be secured against rotation during operation using an anti-rotation element.

Threaded holes (**A**) are provided on the segments of the rotating unions, into which a torque support (**B**) can be screwed. The example shows a pin that is restrained in a fork.

Fig. 6: Example of a possible locking element

4.5.3 Connection of a leakage line

The rotating unions of the 1600 series are designed so that leakages only occur if there is a fault or if they are worn. Every segment in the rotating unions has a leakage connection or a vent (depending on the medium). Refer to the model-specific installation drawing for details. The leakage and ventilation channels are connected to each other inside the rotating union. This means it is sufficient to connect a leakage line to the lowest leakage connection. Unused leakage connections can be left open or closed with plugs.

5 Installation

The union installation is described in an additional manual which is supplied with each rotating union. Please follow the additional instruction "Installation" for a secure and correct installation of the rotating union. The instruction "Installation" is available online under www.deublin.eu.

- Ensure that the person installing the rotating union receives the following information:
 - Position and location of the rotating union in the machine
 - Plan for connection of hoses
 - Position of leakage line
 - Information on installing the locking element provided by the customer
 - Information on the media

6 Information on the Operation



Damage to components through operation without a medium (dry run)

If a segment of the rotating union is intended for use with a lubricating medium, the rotating union may not be operated without this medium. If it is operated without this lubricating medium, the sealing surfaces of the rotating union will be damaged.

- Ensure that the rotating unions are operated with a medium.
- Switch off the plant/machine, if the rotating unions are operated without medium.
- Refer to the model-specific installation drawing to find out whether a particular segment of the rotating union is intended for a lubricating medium.

7 Storage



Note

Damage of component due to incorrect storage

If you store the rotating unions incorrectly, they become leaky or get damaged.

- Store the rotating unions in a dry space between 3 °C and 40 °C.
- Store rotating unions for two years at the most.

8 Maintenance

This chapter provides information on how to extend the service life of the rotating unions by means of maintenance.

8.1 Maintenance Intervals

You can avoid early wear of the rotating unions, if you adhere to the maintenance intervals described herein.



Warning

Risk of injury due to hot surfaces

The rotating unions are heated by the temperature of the medium and through frictional heat.

Skin contact with these heated rotating unions can cause severe injuries.

- Before starting to work on the rotating union, allow the machine to cool down.
- Use safety gloves and PPE (Personal Protective Equipment) protecting against heat depending on the application of the rotating unions.

8.2 Daily Inspection

Check the rotating unions for tightness.



Warning

Risk of injuries due to applied line pressure

If you have to work on the rotating union and feed pressure of the medium is applied or there is residual pressure in the piping system of the machine, the medium can escape under pressure when releasing the connections. You and other people may suffer severe injuries.

- Ensure that no feed pressure is applied.
- Ensure that there is no residual pressure in the piping system.

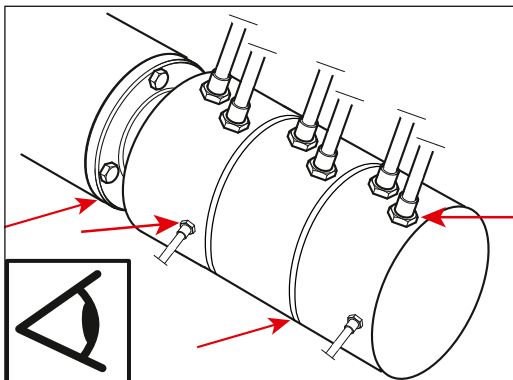

Fig. 7: Inspect visually

During operation of the machine, leakages may occur at the connections and hoses depending on the requirements to the rotating unions.

- Carry out daily visual inspections in order to check whether leakages occurred at the connections (see arrows).

If you detect leakage:

1. Stop the machine.
2. Replace the defective hoses with new ones.
3. Seal leaking connections.
4. If the rotating union is worn and leaks, replace it with a new one.

8.3 Maintenance after Operating Hours

This chapter describes how to relubricate the rotating unions.



Info

Rotating unions of the series 1600 are lubricated in the factory for the entire service life. The rotating unions are already lubricated in the factory and delivered ready-to-be-installed.

9 Trouble Shooting

This chapter provides the following information:

1. Which problem may occur?
2. What can be the cause of the problem?
3. How can you eliminate this problem?



Info

Do not disassemble the rotating unions for repair. This invalidates the warranty claim.

9.1 Potential Causes for Errors and their Elimination



Warning

Risk of injuries due to applied line pressure

If you have to work on the rotating union and feed pressure of the medium is applied or there is residual pressure in the piping system of the machine, the medium can escape under pressure when releasing the connections. You and other people may suffer serious injuries.

- Ensure that no feed pressure is applied.
- Ensure that there is no residual pressure in the piping system.

Error	Potential causes	Elimination
Rotating union is leaky after installation	Incorrect installation	<ol style="list-style-type: none"> 1. Stop the machine. 2. Ensure that the connections are sealed according to the manual "Installation". 3. Ensure that all hoses are installed without stress. 4. Ensure that all seal faces are clean.
	Seal faces of the rotating union (segments) are damaged	<ol style="list-style-type: none"> 1. Pack rotating union. 2. Send rotating union to Deublin for overhaul/service.
	Rotating union is defective	
Rotating union leaks before the end of the expected service life	Medium is contaminated	<ol style="list-style-type: none"> 1. Stop the machine. 2. Drain medium. 3. Send rotating union to Deublin for overhaul/service, if required. 4. Mount new filter. 5. Flush the piping system of the machine. 6. Fill in new medium.
	Rotating union is not designed for the respective application	<ol style="list-style-type: none"> 1. Ensure that the correct Deublin Rotating Union is used. 2. Contact Deublin if required.
Rotating union runs untrue or wobbles	Thread and/or concentricity outside the admissible tolerance.	<ol style="list-style-type: none"> 1. Stop the machine. 2. Remove rotating union. 3. Manufacture new thread or flange. 4. Install rotating union.
	Rotating union is mounted incorrectly.	

9.2 Pack Rotating Union for Transport

The rotating union has to be protected against mechanical impact and humidity during transport to ensure that the rotating union will arrive at Deublin without being damaged.

1. Dismount the rotating union in reverse order of the installation (see Installation).
2. Ensure that the rotating union is free from the respective media.
3. Use a cardboard box which is suitable for the weight of the rotating union.
4. Cushion the base of the cardboard box with a soft material, e.g. air bubble film.
5. Wrap the rotating union with a soft material, e.g. air bubble film.
6. Ensure that no packing material or dirt can penetrate the opening of the rotating union.
7. Position the rotating union in the middle of the cardboard box.
8. Fill the free space around the rotating union with newspaper or another suitable material.
9. Close the cardboard box by means of tape.

10 Disposal

10.1 Dispose of Packaging

- Dispose of the packaging (cardboard box and plastics) according to the national standards, regulations and directives.

10.2 Dispose of Rotating Union

Mainly, the rotating unions consist of metals, which can be reused within the reclamation of scrap. Decontaminate unions / parts and dispose of in an “Environmentally Friendly” way.

- Dismount the rotating union in reverse order to the installation (see Installation).
- Flush the rotating union.
- Collect the dirty flushing media.
- Dispose of the collected flushing media according to the national standards, regulations and directives.
- If you use thermal oil, please observe the instructions of the thermal oil manufacturer.
- Dispose of the rotating union according to the national standards, regulations and directives.

In case of repair, Deublin disposes of all used parts.

11 Spare Parts

The rotating unions have a limited service life and include wearing parts. All static and dynamic sealing elements of a component are considered wearing parts, as well as ball bearings.



Info

Note

If you do not want to repair your rotating union on your own, Deublin will be pleased to help you. If requested, Deublin will exchange all wearing parts and clean all components of the rotating union. Before repaired rotating unions leave the premises, they will be subjected to an operational check. The repaired rotating union is returned with a standard “Deublin Warranty” valid for 12 months.

Reliability

Many years' experience, ongoing liaison with customers, innovations sourced inhouse and from suppliers place Deublin in a position providing reliable Rotating Unions at the highest level.

When it comes to concrete applications, maximum service life is guaranteed by matching the sealing to the respective medium.

The service life is also equally maximized by maintaining cleanliness when storing and handling the Rotating Union and by adhering to the guidelines issued by Deublin in respect of the conditions on the customer's premises.

AMERICA

DEUBLIN USA

2050 Norman Drive
Waukegan, IL 60085-6747 U.S.A
Phone: +1 847-689 8600
Fax: +1 847-689 8690
E-Mail: cs@deublin.com

DEUBLIN Brazil

Rua Fagundes de Oliveira, 538 - Galpão A11
Piraporinha
09950-300 – Diadema - SP - Brasil
Phone: +55 11-2455 3245
Fax: +55 11-2455 2358
E-Mail:
deublinbrasil@deublinbrasil.deublin.com.br

DEUBLIN Mexico

Norte 79-A No. 77, Col. Claveria
02080 Mexico, D.F.
Phone: +52 55-5342 0362
Fax: +52 55-5342 0157
E-Mail: deublinmexicocs@deublin.com

ASIA

DEUBLIN China

No. 2, 6th DD Street,
DD Port Dalian, 116620, China
Phone: +86 411-8754 9678
Fax: +86 411-8754 9679
E-Mail: info@deublin.cn

Shanghai Branch Office

Room 15A07, Wangjiao Plaza
No. 175 East Yan'an Road, Huangpu District
Shanghai 200002
Phone: +86 21-5298 0791
Fax: +86 21-5298 0790
E-Mail: info@deublin.cn

DEUBLIN Asia Pacific

51 Goldhill Plaza
#17-02 Singapore 308900
Phone: +65 6259-92 25
Fax: +65 6259-97 23
E-Mail: deublin@singnet.com.sg

DEUBLIN Japan

2-13-1, Minamihanayashiki, Kawanishi City
Hyogo 666-0026, Japan
Phone: +81 72-757 0099
Fax: +81 72-757 0120
E-Mail: customerservice@deublin.jp

2-4-10-3F, Ryogoku, Sumida-ku
Tokyo 130-0026, Japan
Phone: +81 35-625 0777
Fax: +81 35-625 0888
E-Mail: customerservice@deublin.jp

1-9-2-4F, Mikawaanjo-cho, Anjo City
Aichi 446-0056, Japan
Phone: +81 566-71 4360
Fax: +81 566-71 4361
E-Mail: customerservice@deublin.jp

DEUBLIN Korea

Star Tower #1003, Sangdaewon-dong 223-
25, Jungwon-gu, Seongnam-si, Gyeonggi-do,
South Korea
Phone: +82 31-8018 5777
Fax: +82 31-8018 5780
E-Mail: customerservice@deublin.co.kr

EUROPE

DEUBLIN Germany

Florenz-Allee 1
55129 Mainz, Germany
Phone: +49 6131-49980
E-Mail: info@deublin.de

DEUBLIN Italy

Via Guido Rossa 9 - Loc. Monteveglio
40053 Comune di Valsamoggia (BO), Italy
Phone: +39 051-835611
Fax: +39 051-832091
E-Mail: info@deublin.it

DEUBLIN Austria

Lainzer Straße 35
1130 Wien, Austria
Phone: +43 1-8768450
Fax: +43 1-876845030
E-Mail: info@deublin.at

DEUBLIN France

61 Bis, Avenue de l'Europe
Z.A.C de la Malnoue
77184 Emerainville, France
Phone: +33 1-64616161
Fax: +33 1-64616364
E-Mail: service.client@deublin.eu

DEUBLIN Spain

C/ Lola Anglada, 20
08228 Les Fonts (Terrassa), Spain
Phone: +34 93-221 1223
E-Mail: deublin@deublin.es

DEUBLIN United Kingdom

6 Sopwith Park, Royce Close, West Portway
Andover SP10 3TS, UK
Phone: +44 1264-33 3355
Fax: +44 1264-33 3304
E-Mail: info@deublin.co.uk

DEUBLIN Poland

ul. Bierutowska 57-59
51-317 Wrocław, Poland
Phone: +48 71-3528152
Fax: +48 71-3207306
E-Mail: info@deublin.pl