



## Rotating Unions



Series	
<b>6000</b>	<b>6005</b>
Model	
6200	6205
6250	6255
6300	6305
6400	6405

## Content

1	For your Safety	3
1.1	Intended Use	3
1.1.1	Application one-way version (Mono)	4
1.1.2	Application two-way version (Duo)	4
1.2	Misuse	4
1.3	Safety Instructions	5
1.3.1	Hazards due to hot surfaces	5
1.3.2	Hazards by incorrect hoses	5
1.3.3	Hazards due to the media	5
1.3.4	Hazards by faulty installation	6
1.4	Structure of Pictograms	6
2	Information as to this Manual	6
3	Information on the Name Plate	7
4	Information on the Design	7
4.1	Filtering of the Medium	7
4.2	Connecting Options of the Rotating Union at the Machine Shaft	8
4.3	Options of Hose Installation	8
4.3.1	Connection of hose to the rotating union	8
4.3.2	Hose connection for hoses with SAE flange	9
5	Installation	9
6	Information on the Operation	9
7	Storage	9
8	Maintenance	10
8.1	Maintenance Intervals	10
8.2	Daily Inspection	10
8.3	Maintenance after Operating Hours	10
8.3.1	Allowed lubricants	11
8.3.2	Volume of grease for lubrication	11
8.3.3	Relubrication intervals for series 6000	11
8.3.4	Relubrication intervals for 6005	12
8.3.5	Lubricate the rotating union	13
9	Trouble Shooting	13
9.1	Potential Causes for Errors and their Elimination	13
9.2	Pack Rotating Union for Transport	14
10	Disposal	15
10.1	Dispose of Packaging	15
10.2	Dispose of Rotating Union	15
11	Spare Parts	15

## 1 For your Safety

This chapter provides information on the safe handling of Deublin rotating unions.

- For your own safety and the safety of other people read this operating manual carefully and completely prior to working on or with Deublin rotating unions.
- This operating manual exclusively describes the rotating unions of the manufacturer Deublin. In the further description/explanation the name “Deublin” is left out for a better readability.
- This operating manual is a material part of the specified rotating unions. The operator is responsible for the personnel to take note of this manual.
- The operator of the rotating unions shall not make any modifications or attachments to and retrofitting of the rotating union without the manufacturer’s consent.

### 1.1 Intended Use

The rotating unions of the series 6000 and 6005 supply the feeding of the following media: Water and Thermal oil (not all designs of series 6000 are suitable for thermal oil. If you want to use a series 6000 model for thermal oil, please contact Deublin.)

Series	Model	Temperature range (°C)	Medium	
			Water	Thermal oil
6000	6200	up to 120°	✓	X
6005	6205	up to 160°	✓	✓
6000	6250	up to 120°	✓	X
6005	6255	up to 160°	✓	✓
6000	6300	up to 120°	✓	X
6005	6305	up to 160°	✓	✓
6000	6400	up to 120°	✓	X
6005	6405	up to 160°	✓	✓

The rotating unions referred to are designed for non-potentially explosive environments and non-combustible media. Details on the operating range of the rotating unions are provided in the catalogue and/or the model-specific installation drawing.

The rotating unions of the series 6000 and 6005 can be used as one-way or two-way version depending on the type of connection.

## 1.1.1 Application one-way version (Mono)

For the one-way version, models are available which can be installed at the machine shaft from the outside or in the machine shaft.

### Rotating union externally mounted

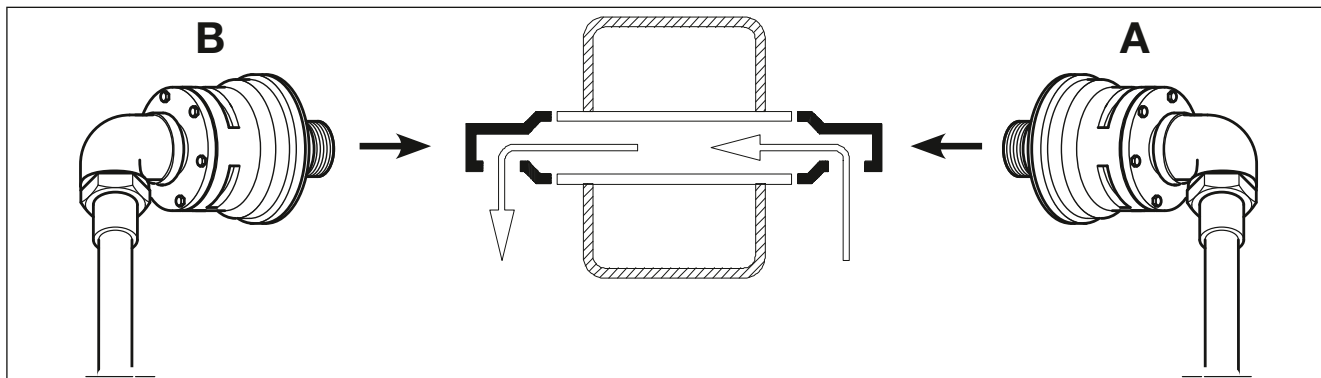
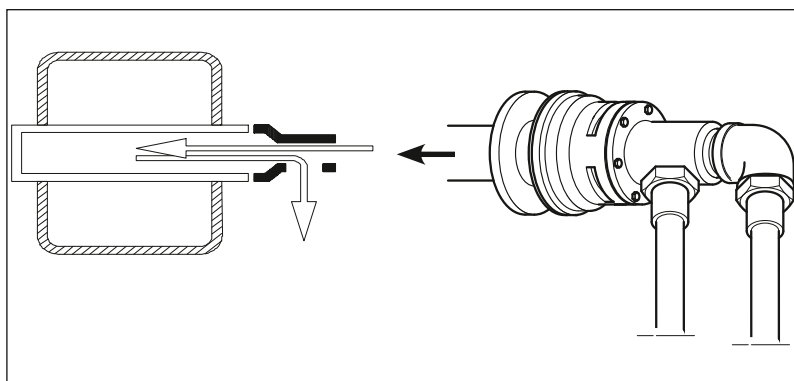

Fig. 1: Schematic diagram one-way version (Mono – externally mounted)

One one-way version of the rotating union is mounted at each of the two ends of the roller. The rotating union (A) conveys the medium into the roller. The rotating union (B) conveys the medium into the piping system of the machine.

## 1.1.2 Application two-way version (Duo)



The rotating unions of the 6000 and 6005 series are also available as two-way model (Duo).

Through the elbow, the medium is guided through a supply tube into the machine shaft. The escaping medium is collected by the same rotating union and fed into the piping system of the machine through the radial connection.

Fig. 2: Schematic diagram two-way version (Duo)

## 1.2 Misuse

This chapter provides information on known misuse of rotating unions of the 6000 and 6005 series. The rotating unions are not suitable for the areas and applications described herein. Use in such areas or for such applications constitutes a misuse endangering people and machines and is therefore prohibited.

### Prohibition for the following areas:

**Potentially explosive areas**

The rotating unions of the 6000 and 6005 series shall not be used in potentially explosive areas, as they are not approved for the requirements in potentially explosive areas. Operation in such areas may cause explosions.

**Food**

Food, cleaning and disinfectant residues cannot be removed from the rotating unions. People may suffer poisoning.

**Prohibition for the following applications:**

- Conveying of combustible media or hydrocarbons**  
Combustible media or hydrocarbons may ignite or cause explosions.
- Connection to a piping system with excessive pressure**  
If excessive pressure is applied to the rotating unions, supply pipes can come off and cause personal injury or property damage.
- Operation without lubrication**  
Dry operation (without medium) of the rotating union causes damage to the axial face seals.
- Connection to fixed pipes**  
If connection is via fixed pipes, the rotating unions may leak and the ball bearings may get damaged.
- Conveying of media which are too hot**  
If the media exceed the maximum admissible temperature for the rotating union, the static seals (elastomeric seals) can be damaged which may result in leaky rotating unions and personal injury or property damage.
- Conveying of vapour**  
Escaping vapour may injure people seriously.

This list is not comprehensive and will be updated with results from product observation.

### 1.3 Safety Instructions

This chapter provides information on the hazards through rotating unions.

#### 1.3.1 Hazards due to hot surfaces

The rotating unions are heated by the temperature of the medium. Skin contact with heated rotating unions can cause injuries.

- Use safety gloves and PPE (Personal Protective Equipment) protecting against heat when handling the rotating union.
- Attach a clearly visible danger sign visibly on/next to the rotating union in order to warn of danger.

#### 1.3.2 Hazards by incorrect hoses

For the connection of the rotating union to the machine, you have to choose appropriate hoses for the respective medium, which meet, the specifications for the application.

If you use incorrect hoses, the latter may become porous or burst. This can cause personal injury and/or property damage to components of the machine.

- In case of the media water and thermal oil, use hoses which are suitable for the maximum system pressure of the machine and the maximum temperature of the media.

#### 1.3.3 Hazards due to the media

When working on the rotating union, injuries can be caused by skin or eye contact with the media.

- Observe the safety instructions for the flow media. Observe the COSHH Safety Data Sheet for the flow media.

### 1.3.4 Hazards by faulty installation

If the rotating unions are installed incorrectly, hoses and connections may become leaky. The medium can escape. Depending on the medium, personal injury or property damage to the components of the machine may occur.

- Before installing the rotating union ensure that no feed pressure and no residual pressure is applied to the pipeline system of the machine.
- Install the rotating union on the machine using hoses only, in order to avoid stress on the rotating union.
- Install the hoses free from stress.
- Install the hoses to the rotating union prior to mounting it at the machine shaft. Hoses with SAE connection are excluded.

## 1.4 Structure of Pictograms

This chapter provides information on the meaning of the pictograms used in the manual.



Warning

### Warning

Potentially dangerous situation, which may result in death or serious injury.



Note

### Note

Potentially harmful situation in which the product or surrounding objects can be damaged.



Info

### Application notes

and other useful information.

---

## 2 Information as to this Manual

---

The copyright as to this manual remains with Deublin. Subject to changes!

- You can download the latest version of this manual under [www.deublin.eu](http://www.deublin.eu).
- Always use the latest version of the operating manual.

### 3 Information on the Name Plate

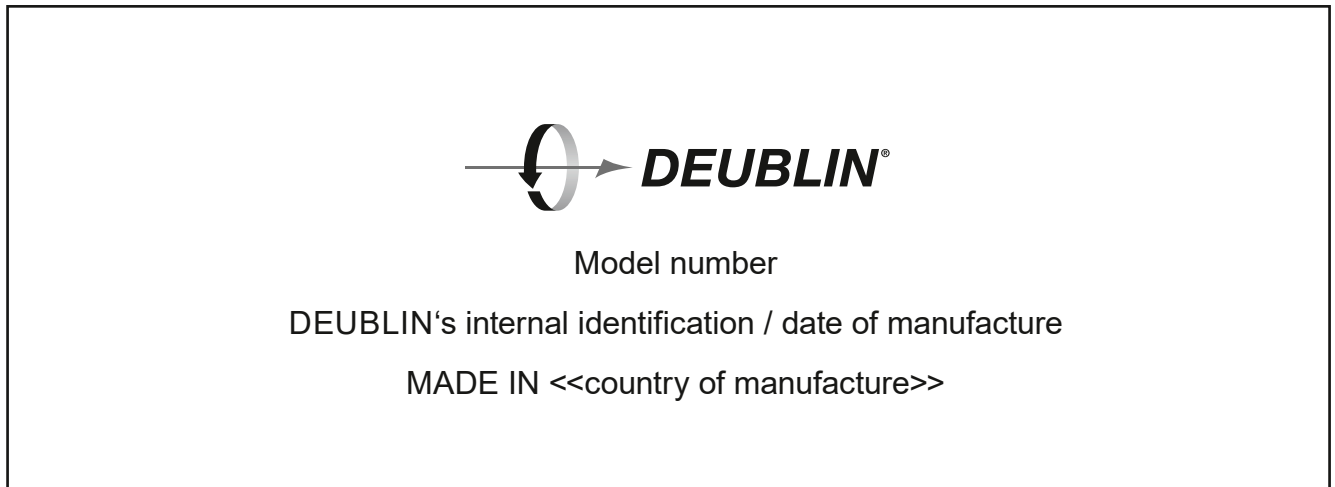

Fig. 3: Name plate

The coding of the model number is described in the catalogue.

### 4 Information on the Design

This chapter provides information as to which items have to be observed in the design in order to have a positive effect on the service life of the rotating union.



You can obtain the drawings of the rotating unions from Deublin in order to integrate the rotating union in your drawing.

#### 4.1 Filtering of the Medium

Unfiltered media with a particle size of more than 60 µm result in increased wear of the rotating union.



The larger the particles in the media, the higher the wear of the rotating union is.

- Insert a filter in front of the rotating union which filters particles with a size of 60 µm and larger from the media.

## 4.2 Connecting Options of the Rotating Union at the Machine Shaft

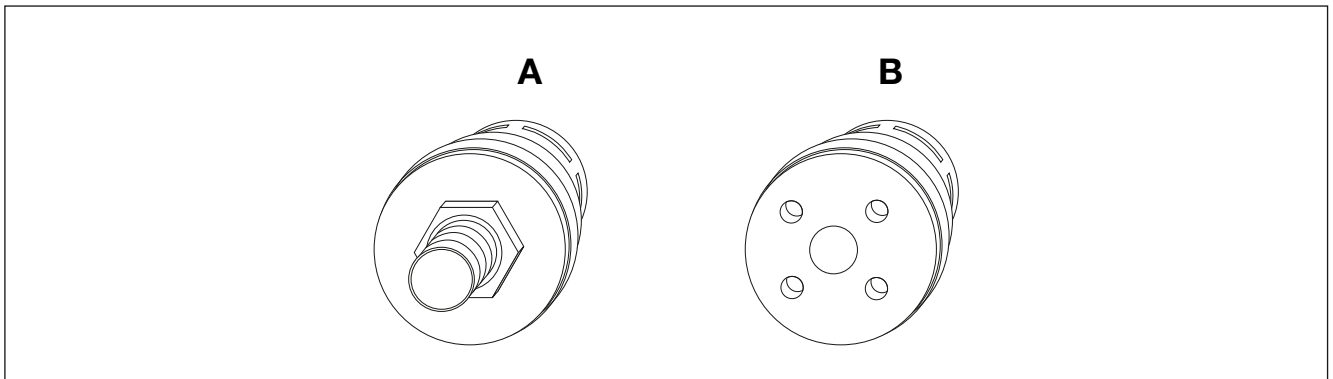

Fig. 4: Options for the installation on the machine shaft

The rotating unions can be fastened on the machine shaft by screwing **(A)** or by means of a flange **(B)** depending on the rotating union.

## 4.3 Options of Hose Installation

The following examples show how to install the hoses at the rotating unions.

These connecting options ensure that the hoses do not transfer stress to the rotating unions when the machine shaft moves.

- Please pay attention to the chapter “1.3 Security Advices” regarding the design.

### 4.3.1 Connection of hose to the rotating union

The hoses must be installed without stress and bends so that they do not apply any forces to the rotating union. The following figures show examples of installation.



If the hoses are to be guided away from the rotating unions vertically and bent by 90°, connect the hoses as shown.

Fig. 5: Hoses bent by 90°



### 4.3.2 Hose connection for hoses with SAE flange



Only possible, if the rotating union is ordered with SAE connections.



The hoses are fastened at the rotating union by means of its SAE flanges using four screws.

Fig. 6: Flange connection

## 5 Installation

The union installation is described in an additional manual which is supplied with each rotating union. Please follow the additional instruction "Installation" for a secure and correct installation of the rotating union. The instruction "Installation" is available online under [www.deublin.eu](http://www.deublin.eu).

- Ensure that the person installing the rotating union receives the following information:
  - Position and location of the rotating union in the machine
  - Plan for connection of hoses
  - Position of leakage line
  - Information on the media

## 6 Information on the Operation



Note

### Damage to components due to missing lubrication (Dry run)

The axial face seals of the rotating unions are lubricated by the medium. If the rotating unions are operated without medium present they are not lubricated and will thus be damaged.

- Ensure that the rotating unions are operated with a medium.
- Switch off the plant/machine, if the rotating unions are operated without medium.

## 7 Storage



Note

### Damage of component due to incorrect storage

If you store the rotating unions incorrectly, they become leaky or get damaged.

- Store the rotating unions in a dry space between 3 °C and 40 °C.
- Store rotating unions for two years at the most.

## 8 Maintenance

This chapter provides information on how to extend the service life of the rotating unions by means of maintenance.

### 8.1 Maintenance Intervals

You can avoid early wear of the rotating unions, if you adhere to the maintenance intervals described herein.



Warning

#### Risk of injury due to hot or cold surfaces

The rotating unions are heated or cooled by the temperature of the medium. Skin contact with these heated or cooled rotating unions can cause severe injuries.

- Before starting to work on the rotating union, allow the machine to cool down.
- Use safety gloves and PPE (Personal Protective Equipment) protecting against heat or cold depending on the application of the rotating unions.

### 8.2 Daily Inspection

Check the rotating unions for tightness.



Warning

#### Risk of injuries due to applied line pressure

If you have to work on the rotating union and feed pressure of the medium is applied or there is residual pressure in the piping system of the machine, the medium can escape under pressure when releasing the connections. You and other people may suffer severe injuries.

- Ensure that no feed pressure is applied.
- Ensure that there is no residual pressure in the piping system.

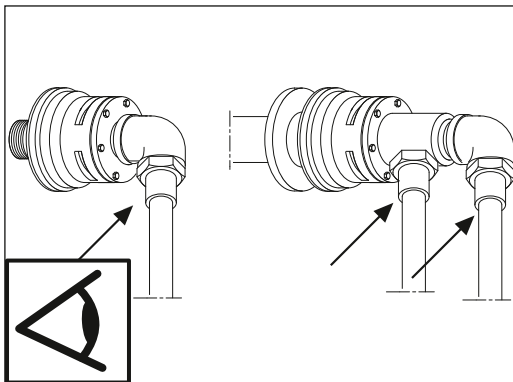

Fig. 7: Inspect visually

During operation of the machine, leakages may occur at the connections and hoses depending on the requirements to the rotating unions.

- Carry out daily visual inspections in order to check whether leakages occurred at the connections (see arrows).

If you detect leakage:

1. Stop the machine.
2. Replace the defective hoses with new ones.
3. Seal leaking connections.
4. If the rotating union is worn and leaks, replace it with a new one. Repair kits for various models can be obtained from Deublin.

### 8.3 Maintenance after Operating Hours

This chapter describes how to relubricate the rotating unions.



Info

The indicated volumes of grease and intervals for relubrication are based on experience resulting from the information of the manufacturer of the lubricant and the operating parameters of the rotating unions. The information given herein refers to operating hours depending on the respective speed.

- In case of doubt, consult Deublin.

Lubricate the ball bearings of the rotating unions at the stated lubricating intervals using the listed volume of grease suitable for the operating conditions. If you do not adhere to these instructions, the service life of the ball bearings is reduced.

### 8.3.1 Allowed lubricants

Series	allowed lubricants
6000	TEXACO CHEVRON SRI 2 GREASE NLGI 2
6005	DUPONT KRYTOX XHTRUF KLÜBER BARRIETA L55/0 LUBCON TURMOTEMP II/400

### 8.3.2 Volume of grease for lubrication



Hinweis

#### Damage to the component due to excessive grease

If you put too much grease in the ball bearings, the latter can be damaged.

- Adhere to the stated volumes of grease for lubrication.

Series	Model	Volume of grease (g)	Series	Model	Volume of grease (g)
6000	6200	18	6005	6205	72
	6250	42		6255	136
	6300	68		6305	285
	6400	90		6405	508

### 8.3.3 Relubrication intervals for series 6000

The intervals for relubrication depend on the operating conditions of the rotating unions.

#### Relubrication intervals for light duty operating conditions

Light duty operating conditions are:

- Medium with a temperature of max. 75°C
- Few vibrations
- Little humidity
- Hardly polluted environment

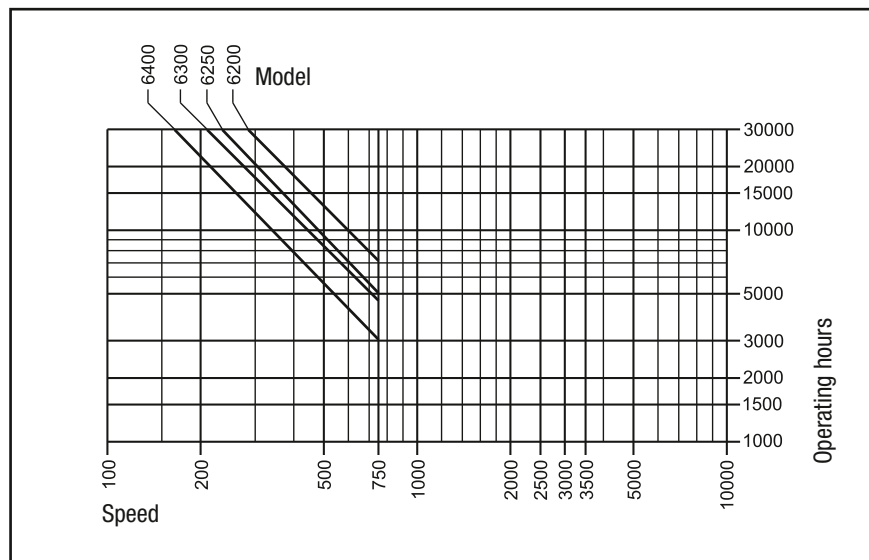

## Relubrication intervals for medium-heavy duty operating conditions

Medium-heavy duty operating conditions are:

- Medium with a temperature of 75° to 120°C
- many vibrations
- much humidity
- extremely polluted environment

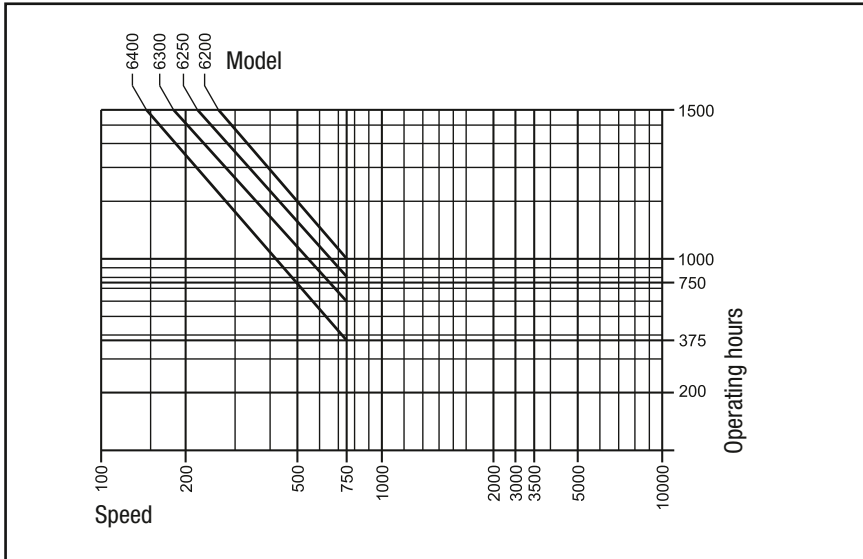

## Relubrication intervals for extreme operating conditions

If the operating conditions exceed the easy and medium-heavy operating conditions, the lubrication interval, volume of grease and grease type have to be adapted to the application.

- Please consult your lubricant supplier.

### 8.3.4 Relubrication intervals for 6005

The relubrication intervals depend upon the conditions of use of the rotating unions.

#### Scope:

These instructions apply to Deublin series 6005 and show the relubrication intervals as well as the required quantities when using the following lubricating greases: KLÜBER BARRIERTA L55/2, LUBCON TURMOTEMP II/400 or DUPONT KRYTOX XHTRUF GREASE.

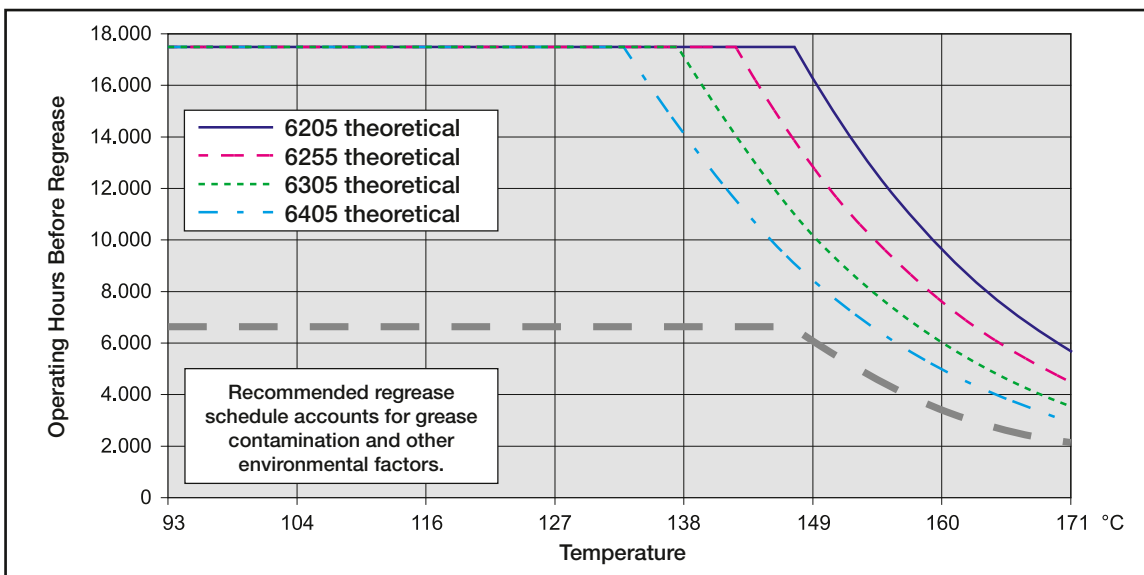

**Relubrication:**

Lubrication quantities with KLÜBER BARRIERTA L55/2, LUBCON TURMOTEMP II/400 or DUPONT KRYTOX XHTRUF GREASE:

Model 6205:	72 g
Model 6255:	136 g
Model 6305:	285 g
Model 6405:	508 g

The above values are taken from the information of the lubricant manufacturers and/or their documents. The actual quantities and intervals are dependant upon the respective conditions of use and require experience gained in respect of the special application.

The relubrication intervals should be started cautiously and then be increased gradually based on the previous values.

**8.3.5 Lubricate the rotating union**

Fig. 8: Attach grease gun for relubrication

The following paragraphs describe how to place the grease gun and inject the stated volume of grease into the ball bearing.

1. Attach the grease gun to the lubricating nipple (see arrow).
2. Ensure that the connector of the grease gun is placed correctly on the lubricating nipple.
3. Actuate the grease gun in order to inject the stated volume of grease into the ball bearing.
4. Count the operating hours for the following lubrication interval.

---

**9 Trouble Shooting**

---

This chapter provides the following information:

1. Which problem may occur?
2. What can be the cause of the problem?
3. How can you eliminate this problem?

**9.1 Potential Causes for Errors and their Elimination****Risk of injuries due to applied line pressure**

If you have to work on the rotating union and feed pressure of the medium is applied or there is residual pressure in the piping system of the machine, the medium can escape under pressure when releasing the connections. You and other people may suffer serious injuries.

- Ensure that no feed pressure is applied.
- Ensure that there is no residual pressure in the piping system.

Error	Potential causes	Elimination
Rotating union is leaky after installation	Incorrect installation	<ol style="list-style-type: none"> <li>1. Stop the machine.</li> <li>2. Ensure that the connections are sealed according to the manual "Installation".</li> <li>3. Ensure that all hoses are installed without stress.</li> <li>4. Ensure that all seal faces are clean.</li> </ol>
	Seal faces of the rotating union are damaged	<ol style="list-style-type: none"> <li>1. Pack rotating union</li> <li>2. Send rotating union to Deublin for overhaul/service.</li> </ol>
	Rotating union is defective	
Rotating union leaks before the end of the expected service life	Medium is contaminated	<ol style="list-style-type: none"> <li>1. Stop the machine.</li> <li>2. Drain medium.</li> <li>3. Send rotating union to Deublin for overhaul/service, if required.</li> <li>4. Mount new filter.</li> <li>5. Flush the piping system of the machine.</li> <li>6. Fill in new medium.</li> </ol>
	Rotating union is not designed for the respective application	<ol style="list-style-type: none"> <li>1. Ensure that the correct Deublin Rotating Union is used.</li> <li>2. Contact Deublin if required.</li> </ol>
Rotating union runs untrue or wobbles	Thread and/or concentricity outside the admissible tolerance.	<ol style="list-style-type: none"> <li>1. Stop the machine.</li> <li>2. Remove rotating union.</li> <li>3. Manufacture new thread or flange.</li> <li>4. Install rotating union.</li> </ol>
	Rotating union is mounted incorrectly.	

## 9.2 Pack Rotating Union for Transport

The rotating union has to be protected against mechanical impact and humidity during transport to ensure that the rotating union will arrive at Deublin without being damaged.



### Risk of injury by high weight

The rotating unions are heavy (depending on the model > 25 kg).

If you lift the rotating unions on your own or without a lifting device, you and other people may suffer injuries.

- Always install the rotating union in pairs.
- Use a crane or lifting device for transport and installation of the rotating union.

1. Dismount the rotating union in reverse order of the installation (see Installation).
2. Ensure that the rotating union is free from the respective media.
3. Use a cardboard box which is suitable for the weight of the rotating union.
4. Cushion the base of the cardboard box with a soft material, e.g. air bubble film.
5. Wrap the rotating union with a soft material, e.g. air bubble film.
6. Ensure that no packing material or dirt can penetrate the opening of the rotating union.
7. Position the rotating union in the middle of the cardboard box.
8. Fill the free space around the rotating union with newspaper or another suitable material.
9. Close the cardboard box by means of tape.

## 10 Disposal



Warning

### Risk of injury by high weight

The rotating unions are heavy (depending on the model > 25 kg).

If you lift the rotating unions on your own or without a lifting device, you and other people may suffer injuries.

- Always install the rotating union in pairs.
- Use a crane or lifting device for transport and installation of the rotating union.

### 10.1 Dispose of Packaging

- Dispose of the packaging (cardboard box and plastics) according to the national standards, regulations and directives.

### 10.2 Dispose of Rotating Union

Mainly, the rotating unions consist of metals, which can be reused within the reclamation of scrap. Decontaminate unions / parts and dispose of in an “Environmentally Friendly” way.

- Dismount the rotating union in reverse order to the installation (see Installation).
- Flush the rotating union.
- Collect the dirty flushing media.
- Dispose of the collected flushing media according to the national standards, regulations and directives.
- If you use thermal oil, please observe the instructions of the thermal oil manufacturer.
- Dispose of the rotating union according to the national standards, regulations and directives.

In case of repair, Deublin disposes of all used parts.

## 11 Spare Parts

The rotating unions have a limited service life and include wearing parts. Wearing parts are excluded from the warranty. All static and dynamic sealing elements of a component are considered wearing parts, as well as ball bearings.

Repair kits are available for several models of the rotating unions and can be obtained from Deublin. Please ask your Deublin Service.

You need special tools and repair instructions for repair of the rotating unions which can be obtained from Deublin as well.



Info

### Note

If you do not want to repair your rotating union on your own, Deublin will be pleased to help you. If requested, Deublin will exchange all wearing parts and clean all components of the rotating union. Before repaired rotating unions leave the premises, they will be subjected to an operational check. The repaired rotating union is returned with a standard “Deublin Warranty” valid for 12 months.



## Reliability

Many years' experience, ongoing liaison with customers, innovations sourced inhouse and from suppliers place Deublin in a position providing reliable Rotating Unions at the highest level.

When it comes to concrete applications, maximum service life is guaranteed by matching the sealing to the respective medium.

The service life is also equally maximized by maintaining cleanliness when storing and handling the Rotating Union and by adhering to the guidelines issued by Deublin in respect of the conditions on the customer's premises.

### AMERICA

#### DEUBLIN USA

2050 Norman Drive  
Waukegan, IL 60085-6747 U.S.A  
Phone: +1 847-689 8600  
Fax: +1 847-689 8690  
E-Mail: cs@deublin.com

#### DEUBLIN Brazil

Rua Fagundes de Oliveira, 538 - Galpão A11  
Piraporinha  
09950-300 – Diadema - SP - Brasil  
Phone: +55 11-2455 3245  
Fax: +55 11-2455 2358  
E-Mail:  
deublinbrasil@deublinbrasil.deublin.com.br

#### DEUBLIN Mexico

Norte 79-A No. 77, Col. Claveria  
02080 Mexico, D.F.  
Phone: +52 55-5342 0362  
Fax: +52 55-5342 0157  
E-Mail: deublinmexicocs@deublin.com

### ASIA

#### DEUBLIN China

No. 2, 6th DD Street,  
DD Port Dalian, 116620, China  
Phone: +86 411-8754 9678  
Fax: +86 411-8754 9679  
E-Mail: info@deublin.cn

#### Shanghai Branch Office

Room 15A07, Wangjiao Plaza  
No. 175 East Yan'an Road, Huangpu District  
Shanghai 200002  
Phone: +86 21-5298 0791  
Fax: +86 21-5298 0790  
E-Mail: info@deublin.cn

#### DEUBLIN Asia Pacific

51 Goldhill Plaza  
#17-02 Singapore 308900  
Phone: +65 6259-92 25  
Fax: +65 6259-97 23  
E-Mail: deublin@singnet.com.sg

#### DEUBLIN Japan

2-13-1, Minamihanayashiki, Kawanishi City  
Hyogo 666-0026, Japan  
Phone: +81 72-757 0099  
Fax: +81 72-757 0120  
E-Mail: customerservice@deublin.jp

2-4-10-3F, Ryogoku, Sumida-ku  
Tokyo 130-0026, Japan  
Phone: +81 35-625 0777  
Fax: +81 35-625 0888  
E-Mail: customerservice@deublin.jp

1-9-2-4F, Mikawaanjo-cho, Anjo City  
Aichi 446-0056, Japan  
Phone: +81 566-71 4360  
Fax: +81 566-71 4361  
E-Mail: customerservice@deublin.jp

#### DEUBLIN Korea

Star Tower #1003, Sangdaewon-dong 223-  
25, Jungwon-gu, Seongnam-si, Gyeonggi-do,  
South Korea  
Phone: +82 31-8018 5777  
Fax: +82 31-8018 5780  
E-Mail: customerservice@deublin.co.kr

### EUROPE

#### DEUBLIN Germany

Florenz-Allee 1  
55129 Mainz, Germany  
Phone: +49 6131-49980  
E-Mail: info@deublin.de

#### DEUBLIN Italy

Via Guido Rossa 9 - Loc. Monteveglio  
40053 Comune di Valsamoggia (BO), Italy  
Phone: +39 051-835611  
Fax: +39 051-832091  
E-Mail: info@deublin.it

#### DEUBLIN Austria

Lainzer Straße 35  
1130 Wien, Austria  
Phone: +43 1-8768450  
Fax: +43 1-876845030  
E-Mail: info@deublin.at

#### DEUBLIN France

61 Bis, Avenue de l'Europe  
Z.A.C de la Malnoue  
77184 Emerainville, France  
Phone: +33 1-64616161  
Fax: +33 1-64616364  
E-Mail: service.client@deublin.eu

#### DEUBLIN Spain

C/ Lola Anglada, 20  
08228 Les Fonts (Terrassa), Spain  
Phone: +34 93-221 1223  
E-Mail: deublin@deublin.es

#### DEUBLIN United Kingdom

6 Sopwith Park, Royce Close, West Portway  
Andover SP10 3TS, UK  
Phone: +44 1264-33 3355  
Fax: +44 1264-33 3304  
E-Mail: info@deublin.co.uk

#### DEUBLIN Poland

ul. Bierutowaska 57-59  
51-317 Wrocław, Poland  
Phone: +48 71-3528152  
Fax: +48 71-3207306  
E-Mail: info@deublin.pl